

Marconi X-Stopper Revisited Simulation

Phil Anderson, WØXI

The following is an LTspice simulation of Graeme Zimmer's (VK3GJZ) [Marconi X-Stopper Revisited](#) crystal set, featured in the November 2009 issue of the [Xtal Set Society Newsletter](#). The coil values were calculated from the turns and T130-2 powdered iron cores he selected as follows:

$$L = A \frac{N^2}{10^4} = 110 \frac{151^2}{10^4} = 250 \text{ [uH]}$$

The effective parallel resistance of tuned circuit tank L3-C3 is

$$R_p = QX_L = 600(\omega L) = 600(6.28 * 1 * 250) = 942k$$

Marconi X-Stopper Coils and Taps				
Core = T130-2 (red)				
	L desired	core	AL	N turns
main	250.00	T-130-2	110	151
tap1	0.01	T-130-2	110	1
tap5	0.10	T-130-2	110	3
tap10	1.00	T-130-2	110	10

Case One

The schematic is reproduced at right, drawn with LTspice. The following assumptions are made: L1, L2 and L3 have a Q of 600, typical for a quality toroidal coil at 1 MHz and the Q of the capacitors (for the next few schematics) is much higher. In addition, an end-fed antenna is assumed with a net reactance represented by Cant and a ground-system loss of 32 ohms, having measured my antenna with a bridge. L1-C1 is used to resonate the antenna at the desired frequency; assume 1 MHz for now. L2-C2 and L3-C3 are also tuned to resonance at 1 MHz, where C1, C2, and C3 are 365pf air variables. Rload represents the total load on the set.

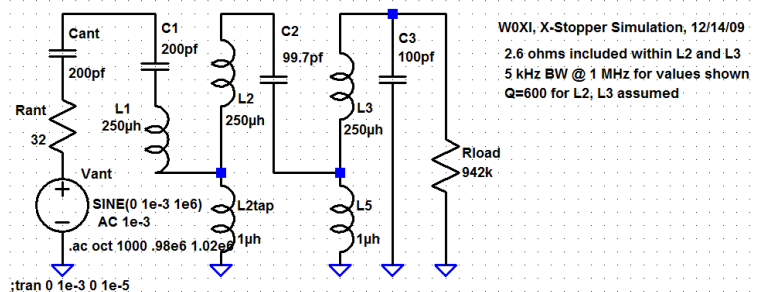

WØXI, X-Stopper Simulation, 12/14/09
2.6 ohms included within L2 and L3
5 kHz BW @ 1 MHz for values shown
Q=600 for L2, L3 assumed

The frequency response, a sweep by LTspice, is noted at right. The bandwidth (BW) achieved is 5 kHz.

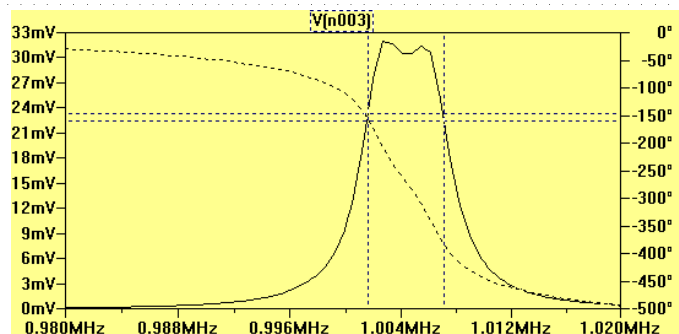

Case Two

Taps L2tap and L3tap were then reduced from 10 to 5 turns, corresponding to 0.1 uH. Note that the frequency response is sharper, bandwidth smaller, and the peak level is lower, as noted below.

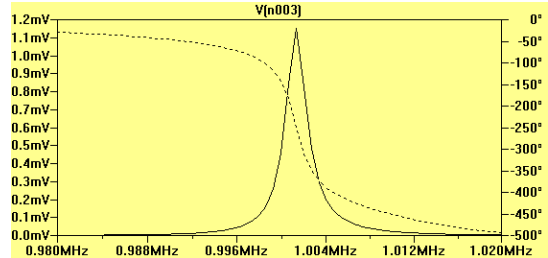
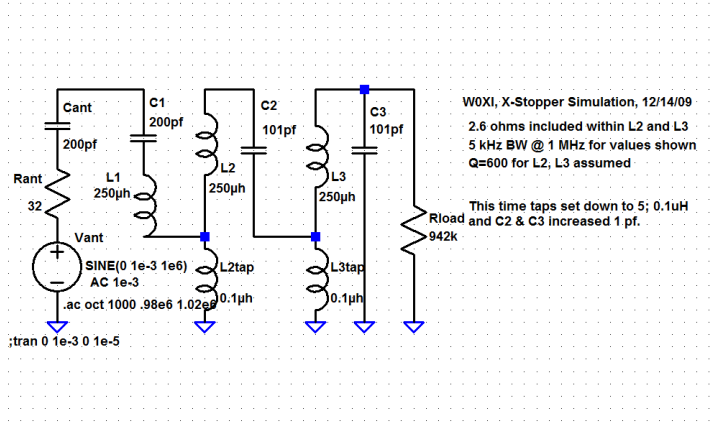

Case Three

Case One and Two assumed that the tuning capacitors had no loss. This is, of course, never true. Capacitor loss increases with frequency and is dependent upon the construction materials, plating, and layout. In this case we added loss to each tank-tuning capacitor - as noted by the resistors Rc2 and Rc3 (2 ohms) - roughly equal to the loss in the associated coils. The schematic and resulting frequency sweep response are shown below.

Given the extra tank loss, a reduction in the loading resistance was in order (for maximum power transfer). I reduced Rload to 600 k, not shown in the schematic. The resulting bandwidth shown is about 6.5 kHz.

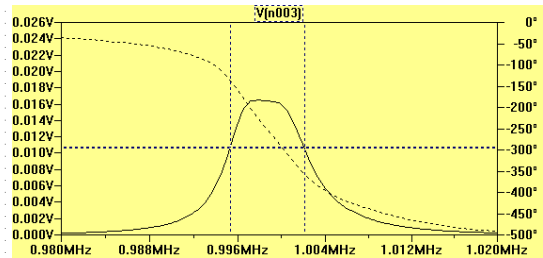
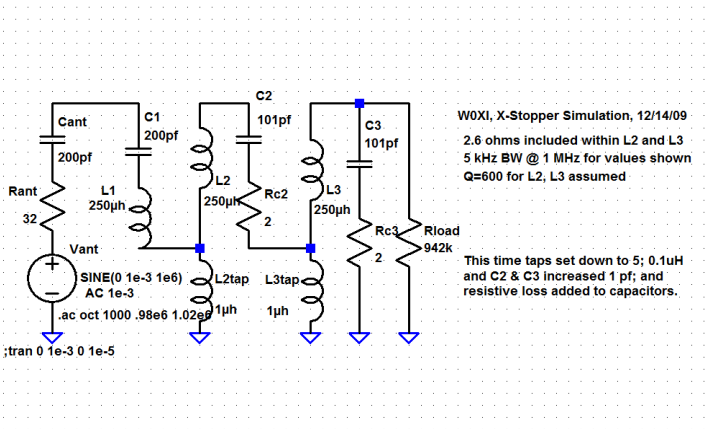

Bandwidth at 1.5 MHz

For the circuit of case 3, the antenna, C2, and C3 were retuned for a response at 1.5 MHz, resulting in the plot at right. Note that the BW increased to 8.9 kHz. At the same time, due to the increase in reactance, R_p of the tanks increased, thus stepping up the peak voltage somewhat. Due to that increase, I changed to R_{load} back up to 900k to match.

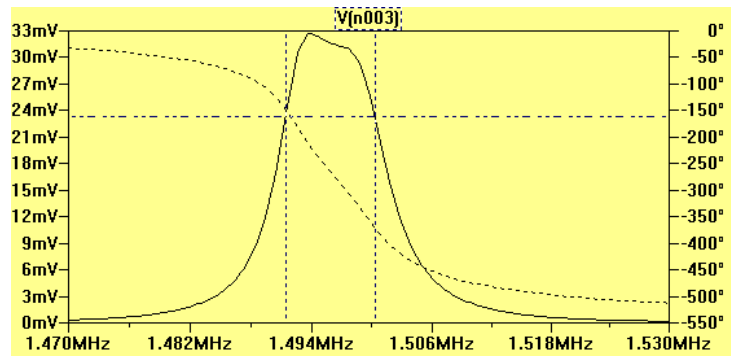

If time permits, my next task shall be to write an impedance expression for this passive network (the total circuit), seeing if the expression reveals further “secrets” of the X-Stopper Revisited Set.

Series Resonance Peaks Along the X-Stopper

As a signal travels through the X-Stopper - using circuit 3 at 1 MHz - it peaks at the center of each series resonant circuit. The responses at the intersections of L1-C1, L2-C2 and L3-C3 are shown right top-down. Tuned off resonance by C1 or C2, the top two responses peak to one side or the other.

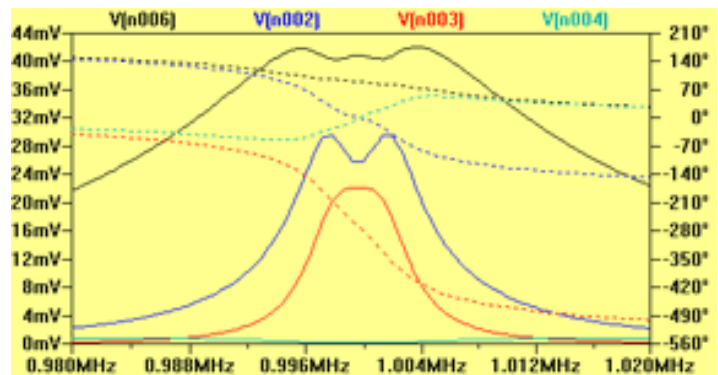

At each tap, the signal from peak resonance is divided down by the $L_x/L_{y\text{tap}}$ divider network. The last stage is not divided down and the peak – coming from that series resonant circuit provides the transformer-like gain for the overall circuit. The previous stages provide the selectivity.

One can surmise that adding more L_x-C_x circuits will continue to narrow the response at the output. However, as more series circuits are “stacked” the peak response at resonance at the output will continue to diminish. Clearly one cannot get away from the sensitivity-selectivity tradeoff.